

XCA130_E 全地面起重机 / All Terrain Crane

技术规格书

Basic technical specifications



130t



62m

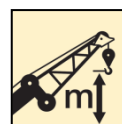

92.5m



2021年6月第1版
First edition , Jun 2021

目录

Contents

目录 Contents	
尺寸参数 Dimensions	3
技术规格 Technical specifications	4-7
重量/作业速度 Weight / Working speeds	8-9
平衡重 Counterweight	10
运输部件尺寸 Transportation components dimension	11-12
臂架组合方案 Boom / Jib combinations	13
主臂 Boom	14-19
副臂 Jib	20-27
符号标识 Symbol glossary	28
主要技术参数表 Table of main technical parameters	29-30
主要配套件明细表 Main parts list	31
注意事项 Notes	32

尺寸参数 Dimensions

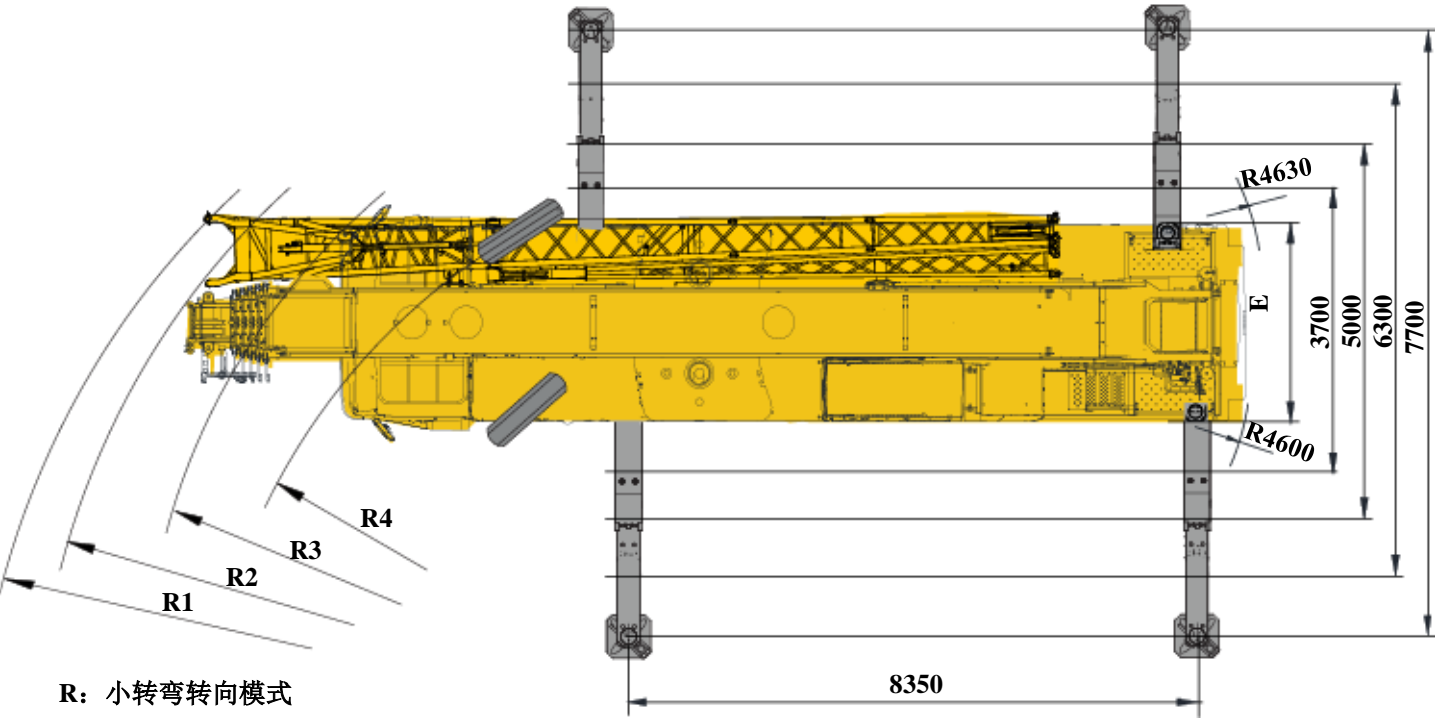
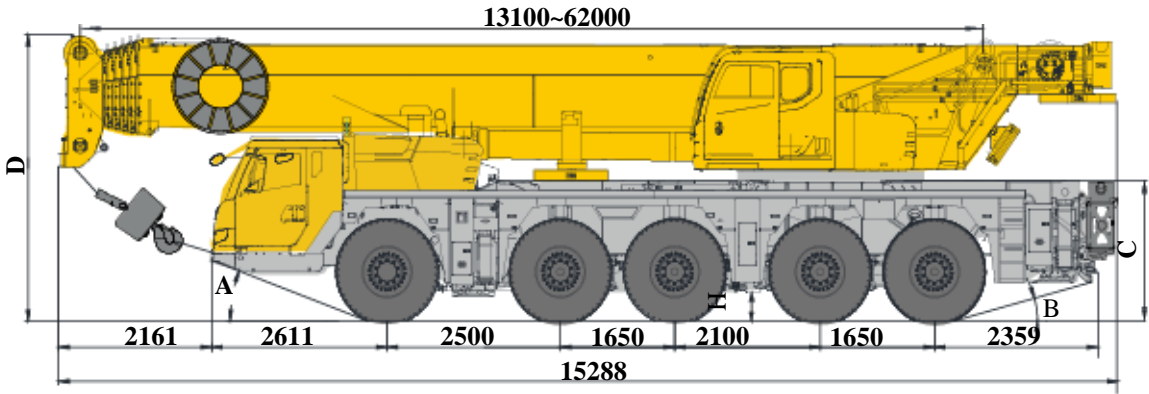

R: 小转弯转向模式



	A	B	C	D	E	R1	R2	R3	R4	H
385/95 R 25 (14.00 R 25)	18°	14°	1911mm	3950mm	2750mm	12150mm	11650mm	10600mm	9000mm	330mm
445/95R25(16.00R25)	19°	15°	1961mm	4000mm	2750mm	12150mm	11650mm	10600mm	9000mm	380mm
525/80R25(20.5R25)	19°	15°	1961mm	4000mm	2850mm	12150mm	11650mm	10600mm	9000mm	380mm

技术规格

Technical specifications

	上车	配置
结构	徐工设计、制造，高强度钢材制造。	●
液压系统	下车发动机驱动变量柱塞泵和齿轮泵用于起升、变幅、伸缩、回转、辅助系统；电控多路换向阀；风冷式液压油散热器；	●
操纵方式	先导电比例操纵，无级调速，由左右2个操纵手柄控制起重机的主要动作。	●
	便捷无线遥控装置，实现作业准备工作。	●
起升机构	液压控制调速，由液压马达通过行星齿轮减速器驱动，内置常闭式制动器并带有平衡阀，装有绳槽卷筒。	主卷 ● 副卷 ○
回转机构	单排四点接触球外齿式回转支承，由液压马达通过行星齿轮减速器驱动，内置常闭式制动器，可连续回转360°，具有动力控制或自由滑转的功能，可无级调速。	●
操纵室	新型钢制操纵室，密封性和防腐性好，安全舒适，全封闭，装有无视野死角的前景窗，安全玻璃，车窗装有遮阳板，推拉式车门，操纵员座椅靠背可倾斜定位，操纵杆安装在座椅两侧的扶手台上。带推拉踏板，方便人员进出。前窗、顶窗装有雨刮器。操纵室内采用人机交互系统控制面板。操纵室可向上翻转约20°。	●
安全装置	液压平衡阀；液压溢流阀；液压双向锁；力矩限制器；三圈保护器；起升高度限位器；风速仪；卷扬监视装置	●
组合配重	总重44.5t，有3.6、6.2、9、15.7、21、25.8、30.5、44.5共8个配重组合方式。	●

集中润滑系统	电脑编程控制，集中润滑点为回转支承、主副起升机构轴承座、变幅油缸上下铰点、操纵室翻转油缸铰点、起重臂后铰点。	●
吊钩	11t吊钩	○
	25吨吊钩	●
	60t吊钩	●
	90t吊钩	●
	130t吊钩	○

臂架系统		
主臂	6节，椭圆形截面的筒形焊接结构，单板式臂头、紧凑式臂尾。单缸插销伸缩机构 主臂长度：13.1m ~ 62m。	●
副臂	由连接架、旋转架和两节桁架结构折叠式副臂组成，具有0°、20°、40°三种安装角，收存于主臂旁。 副臂长度：11m、18.5m 无级变幅	● ○
加长节	7m主臂加长节	○
	7m主臂加长节	○
独立臂头	2.9m独立臂头	○
臂端单滑轮	单滑轮,安装在主臂顶端用于单股钢丝绳起重作业。起重性与主臂相同，但最大起重量不超过7000kg。	●

技术规格

Technical specifications

 Chassis	
Frame	Box structure design with high load-bearing capacity, made of high strength steel. Finite element analysis method is adopted for all working conditions analysis and calculation. High standard testing is realized for the whole manufacturing process. Flaw detection is applied for the key parts to guarantee the high reliability of strength and stability during the load-bearing process. ●
Outrigger	H-type outriggers, two-stage telescoping outrigger beam with push-pull outrigger floats. There are four working positions (fully retracted, half extended, 3/4 extended and fully extended) to meet different requirements. Outrigger control panels controlled by CAN bus are located at both sides of chassis. ● Float dimension: φ450 mm Reaction force of outrigger at max. lifting load: 868kN
Engine	Daimler AG OM471LA, 6 cylinders, diesel. ● Rated power/rpm: 360kw /1700 rpm(EU Stage IV), 360kw/1600rpm(EU Stage V). Rated torque/rpm: 2300N.m/1300rpm(EU Stage IV), 2400N.m/1300rpm(EU Stage V). Emission standard: EU Stage IV/ EU Stage V /EPA Tier 4F. Fuel tank capacity: 460L. Engine cold start ○
Transmission	ZF Germany AMT transmission; 12 forward gears and 2 reverse gears available with retarder. ●
Axles	5-axle chassis with disconnected axle; 2nd, 3rd, 4th and 5th axles for driving, all wheel steering. ●
Suspensions	Advanced independent suspension technology is adopted, and the tires on left and right side move separately to adapt to the road conditions with improved stability; Hydro-pneumatic suspensions have good shock-absorbing effect and automatic leveling function. ● The height of chassis above the ground may be adjusted. Main reducer is attached to the frame, which can be lifted or lowered with frame, leading to improved pass ability. The stroke of suspension cylinder is ±150 mm.

Tires	385/95R25(14.00R25) ○ 445/95R25(16.00R25) ● 525/80R25(20.5R25) ○
Brakes	Service braking: foot pedal operated double-circuit air pressure brake. ● 1st circuit acts on the wheels of 3rd, 4th and 5th axles, 2nd circuit acts on the wheels of 1st and 2nd axles; Parking brake is air-release brake, which acts on the 2nd, 4th and 5th axles, and gives effect by the spring-loaded air chamber on each axle. Auxiliary brake: engine retarding brake and transmission retarding brake. Eddy current retarder ○
Steering	1st and 2nd axles are mechanically steered, 3rd, 4th and 5th axles are of electric-hydraulic proportional steering system. ●
Driver's cab	New full-dimension enclosed cab, luxury and comfort. It is designed to be leakproof, anti-corrosive and shockproof. It is equipped with a windshield offering outstanding visibility, electrical adjustable rear mirrors, electric control washer, electronic lifters of doors and windows, air conditioner, radio cassette player, etc. A simple sleeper for co-driver. ● Beacon lamp at the driver's cab ○
Electrical system	24V DC, two sets of 12V battery in series. ● Generator: 28V-180 A
Work-box	supplied reserved box ○

技术规格





Technical specifications

	Superstructure		
Structural members	Designed and manufactured by XCMG, made of high strength steel.		●
Hydraulic system	Variable plunger pump and gear pump driven by chassis engine are used for lifting, elevating, telescoping, slewing operations and auxiliary systems; Electric control multi-way valve; Air-cooled hydraulic oil radiator;		●
Operating mode	The electric-proportional pilot operation system is equipped with two levers at left and right sides controlling the main movements of the crane, and stepless slewing speed regulation is available. Portable wireless remote control device is equipped to realize the preoperational work for setting up the crane.		●
winch system	Hydraulic control is used for speed regulation. The system is driven by a hydraulic motor through a planetary gear reducer, with a normally closed brake, a balanced valve and a grooved drum equipped.	Main winch	●
		Auxiliary winch	○
Slewing system	A single-row, four-point contact-ball external slewing bearing; the system is driven by a hydraulic motor through a planetary gear reducer with constant-closed brake equipped, and may continuously slew 360°. Power control and free slewing function as well as stepless speed regulation are available.		●
Operator's cab	New fully-enclosed steel cab has better sealing and anti-corrosive properties. It is equipped with a full-view front window. Safety glass and sun shield are used for windows. The cab features a new ergonomic seat design with backrest adjustment and armrests with joysticks fitted. A sliding door and a pull-out step are available to make it easy and safe as access and egress the cab. Wipers are fitted for the windshield and roof window. Control panel with man-machine interactive system is used in operator's cab. The cab can be tilted up to 20°.		●
Safety device	Hydraulic counterbalance valve; hydraulic relief valve; hydraulic double-way valve; LMI; lowering limiter; anti-two block; anemometer; winch monitor		●
Combined counterweight	Total weight is 44.5t. 8 counterweight combinations of 3.6, 6.2, 9, 15.7, 21, 25.8, 30.5 and 44.5 are available.		●

Centralized lubrication system	Controlled by computer program; lubrication points are at slewing ring, bearing pedestals of main winch and auxiliary winch, upper and lower pivots of elevating cylinder, pivot of tilt cylinder and rear pivot of boom.	●
Hook block	11t Hook block	○
	25t Hook block	●
	60t Hook block	●
	90t Hook block	●
	130t Hook block	○

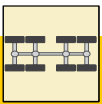
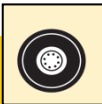
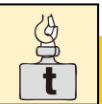
	Boom system	
Boom	6-section boom of 62m with oval profile, welded structure with single-plate boom head and compact boom tail. Single-cylinder pinning telescoping system, Boom length: 13.1m~62m.	●
Jib	The jib consists of a connecting bracket, a rotating bracket and two lattice sections. Three offset angles of 0°, 20° and 40° are available. It is stowed along the side of the boom. Jib length: 11m, 18.5m.	●
Extension	7m Boom extension	○
	7m Boom extension	○
Independent jib head	Independent jib head of 2.9m	○
Single top	Fitted at boom head, used for single line operation. Its lifting performance is the same as that for boom, but the maximum lifting load does not exceed 7000kg.	●

重量 Weight



							总重量 Total weight	整机宽度 Overall Width
12	10×8×10	445/95 R25	11t	6.2	18.5m	√	60t	2750
12	10×8×10	445/95 R25	25t	9	×	×	60t	2750
16.5	10×8×10	445/95 R25	90t	25.8	18.5m	√	82.5t	2750







吊钩最大吊重量 Max. lifting capacity of the hook block	倍率 Parts of line	产品额定吊重量 Rated lifting capacity	吊钩重量 Weight (kg)	吊钩尺寸 Dimensions (mm)	备注 Remarks
130t	14	101t	1200	1907×760×795	双钩 Double hook
90t	10	83t	820	1657×630×590	双钩 Double hook
60t	7	58t	580	1456×630×350	双钩 Double hook
25t	3	25t	400	1439×630×335	单钩 Single hook
11t	1	8.9t	296	744×440×440	单钩 Single hook

重量 Weight



		
385/95 R 25 (14.00 R 25)	1 ~ 80	60%
445/95 R 25 (16.00 R 25)	1~85	60%
525/80R25(20.5R25)		



作业机构 Drive	作业速度 Working speed	最大单绳拉力 Max. single line pull	钢丝绳直径/长度 Rope diameter/ length
	0-130 m/min, 单绳, 第四层 m/min, single line, 4th layer	87kN	20 mm/265 m
	0-130 m/min, 单绳, 第四层 m/min, single line, 4th layer	87 kN	20 mm/205 m
	0-1.65 r/min		
	从-0.5°抬起至82°约65s Approx. 65s for boom elevation from -0.5° to 82°		
	从13.1m伸出至62m约630s Approx. 630s for boom extension from 13.1m to 62m		

平衡重 Counterweight

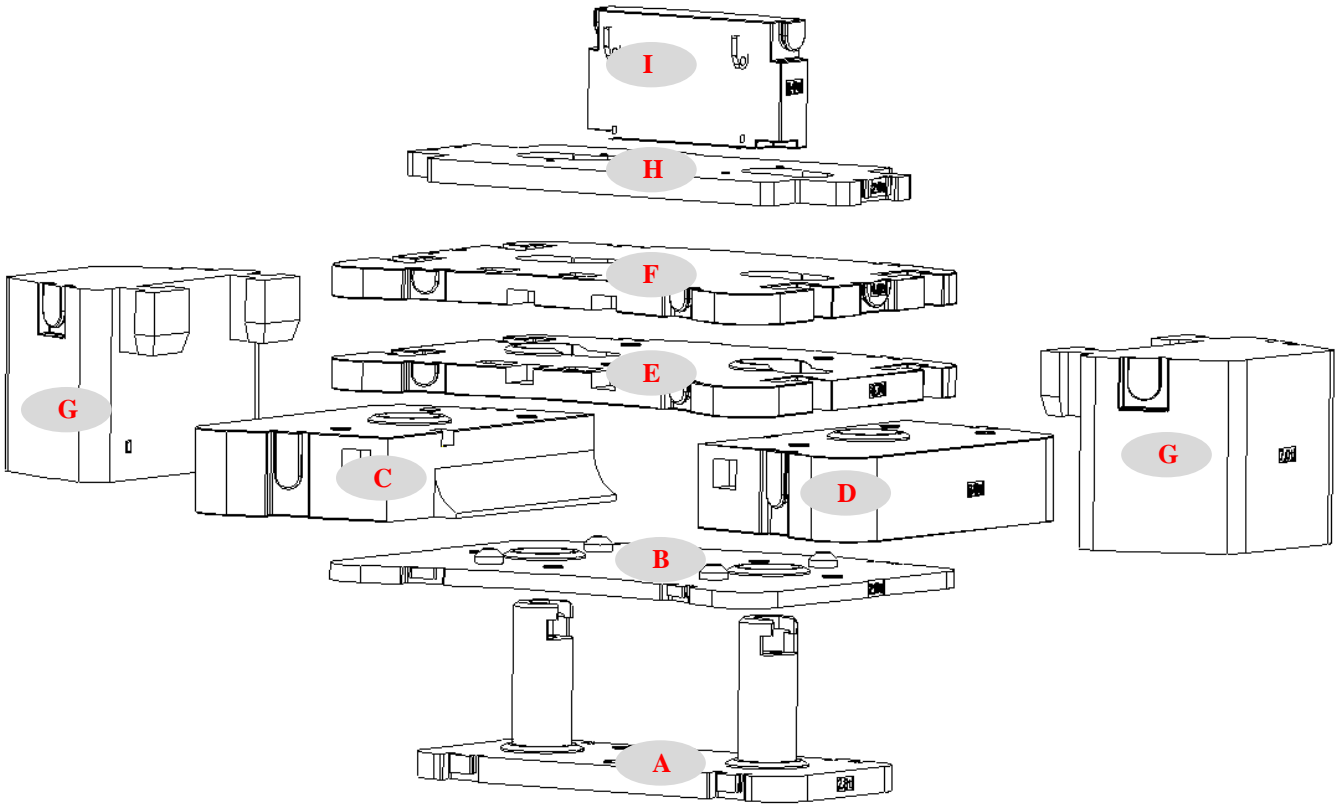

平衡重 Counterweight	A	B	C	D	E	F	G	H	I
尺寸 (长×宽 ×高) m Size (L×W×H) (m)	2380×107 0×883	2740×202 6×154	1270×20 26×462	1270×20 26×462	2740×20 26×186	2740×20 26×160	1092×12 52×982	2740×11 00×120	1200×38 4×650
重量 t Weight (t)	2.6	2.8	6	6	4.7	4.8	7	2.2	1.4

工况模式 Working mode	44.5t	30.5t	25.8t	21t	15.7t	9t	6.2t	3.6t
组合形式 Combinations	I+H+A+B+ C+D+E+F +G*2	I+H+A+B+ C+D+E+F	I+H+A+B+ C+D+F	I+H+A+B+ C+D	I+H+A+E+ F	I+H+A+B	I+H+A	I+H

运输部件尺寸

Transportation components dimension

副臂及支架 2200kg
Jib and the bracket 2200kg

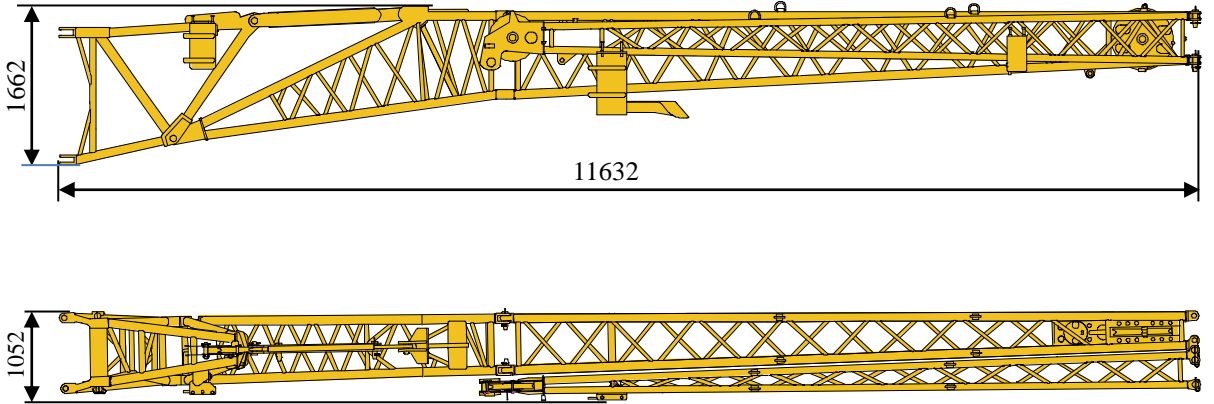

主臂加长节 640kg
Boom extension 640kg

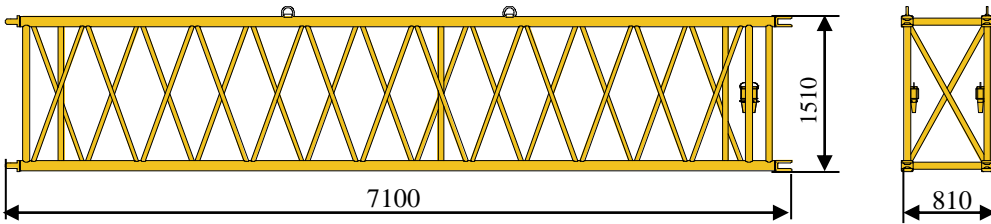

独立臂头 477kg
Independent jib head 477kg

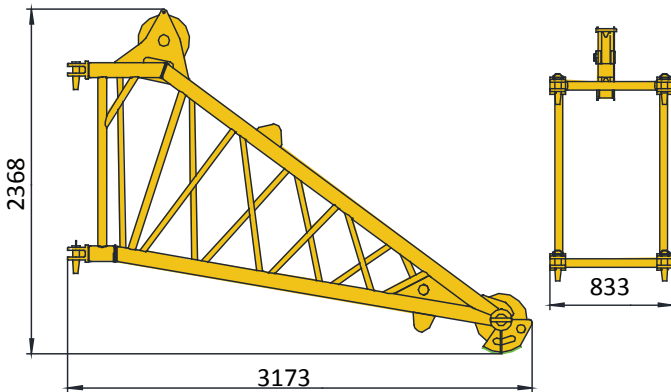

臂端单滑轮60kg
Single top 60kg

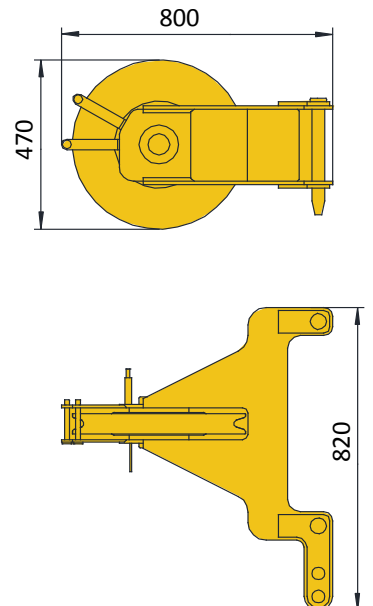

运输部件尺寸

Transportation components dimension

起重钩 4265kg
Hook block 4265kg

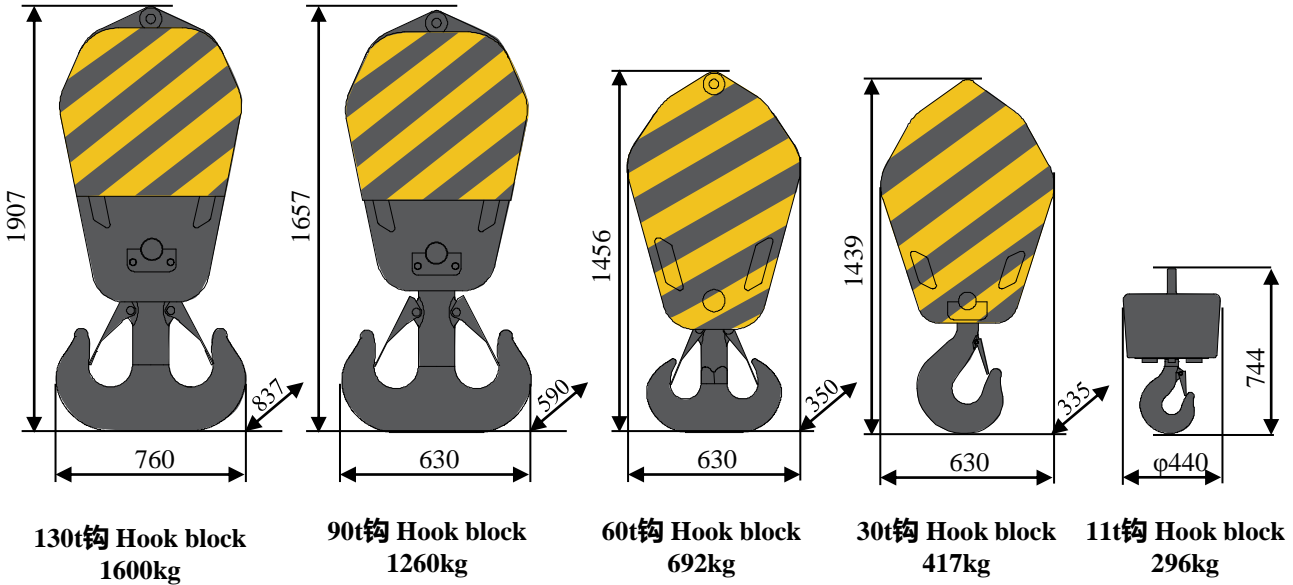

副起升机构 (含钢丝绳) 1409kg
Auxiliary winch (rope included) 1409kg

胶管卷筒 280kg
Hose reel

附加滑轮 42kg
Additional sheave block 42kg

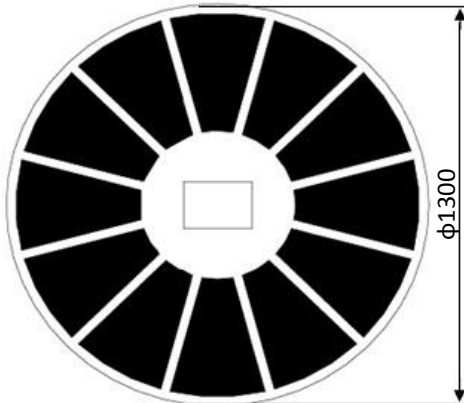
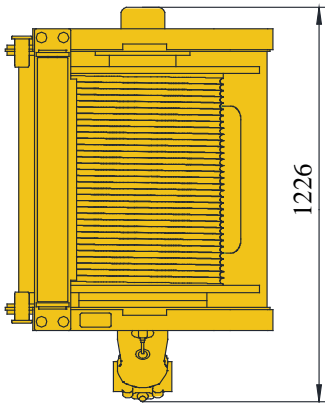
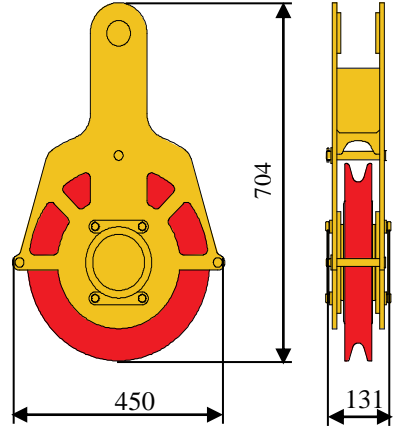
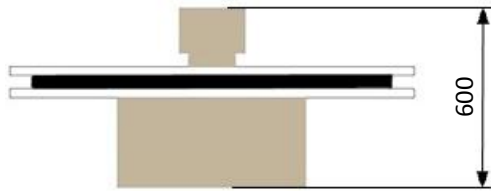
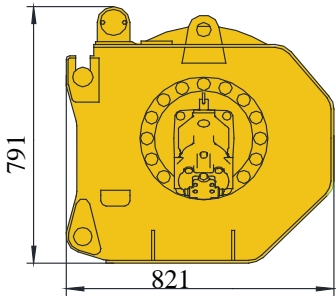

臂架组合方案

Boom / Jib combinations

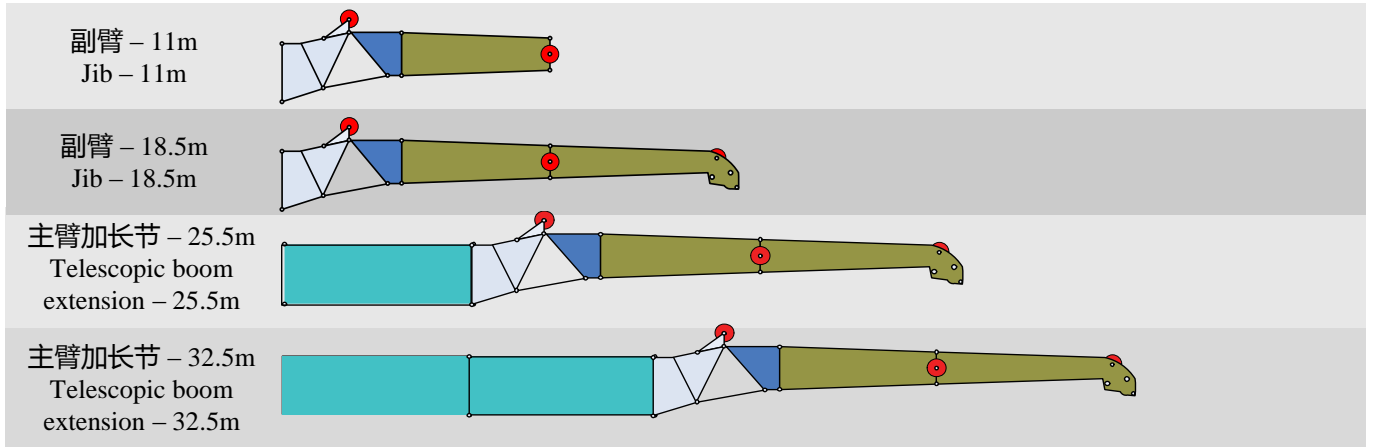

部件 Component	结构形式 Structure	尺寸 (长×宽×高) mm Size (L×W×H) (mm)	重量 kg Weight (kg)
连接架 Connecting bracket		1934×710×1300	373
旋转架 Rotating bracket		3400×580×800	381
主臂加长节 Telescopic boom extension		7000*1300*710	640
一节副臂总成 First jib section assembly		7030×510×800	616
二节副臂总成 Second jib section assembly		6970×330×450	364

臂架组合方案

Boom / Jib combinations

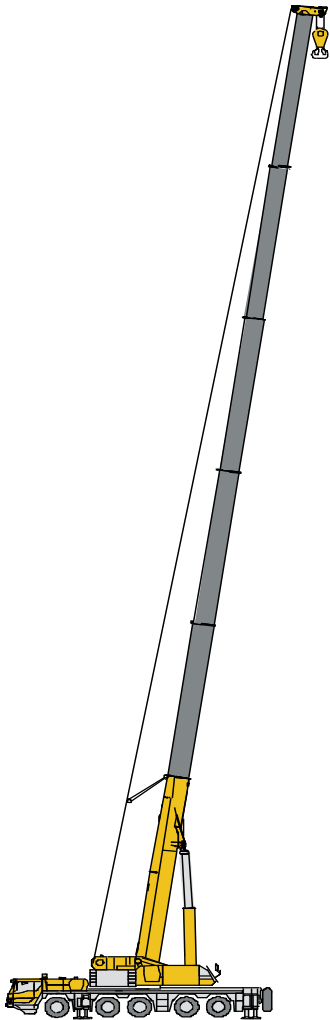

主臂
Telescopic boom

T : 13.1~62m

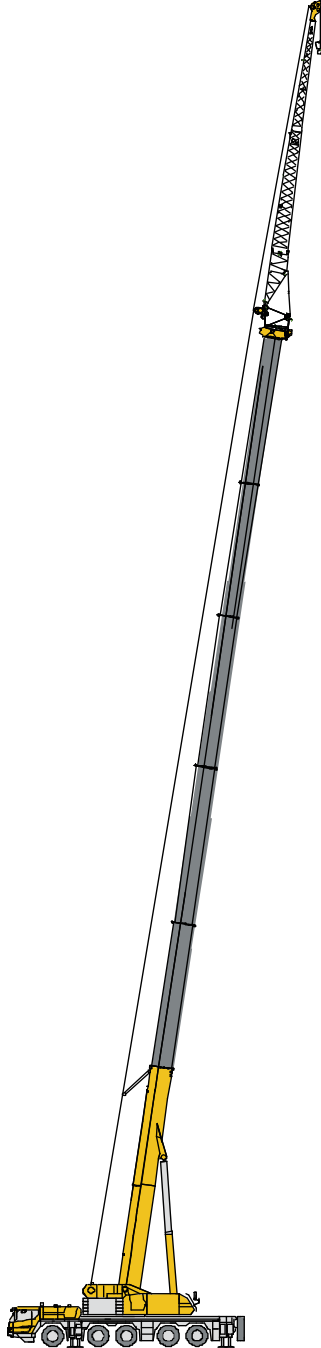

副臂
Jib

T : 40.1~62m
J : 11~18.5 m

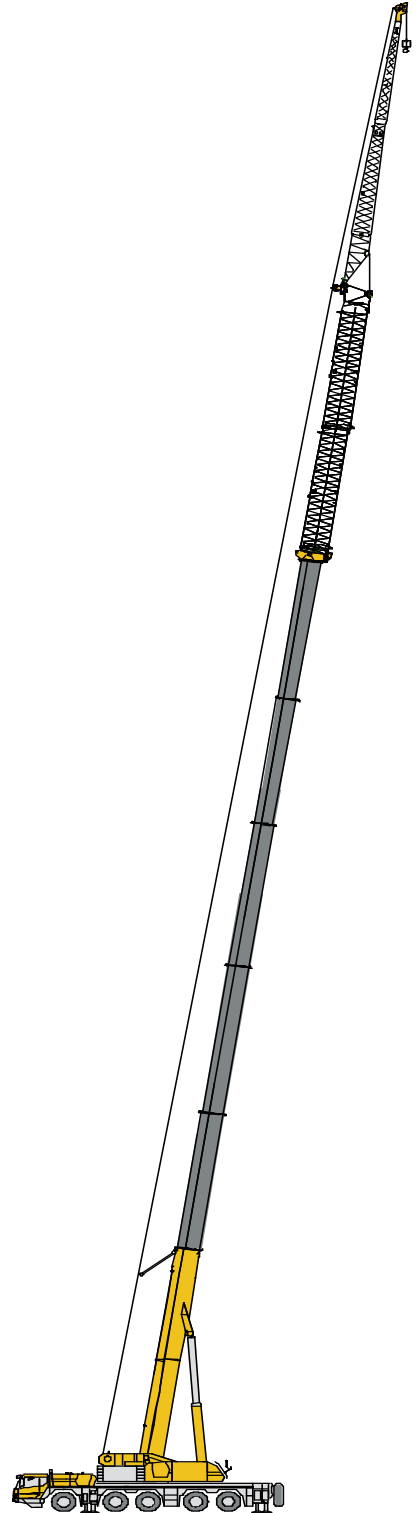

主臂加长节
Telescopic boom extension

T : 58.1~62m
I : 14m
J : 11~18.5m

起升高度曲线图
Lifting height chart

主臂
Boom

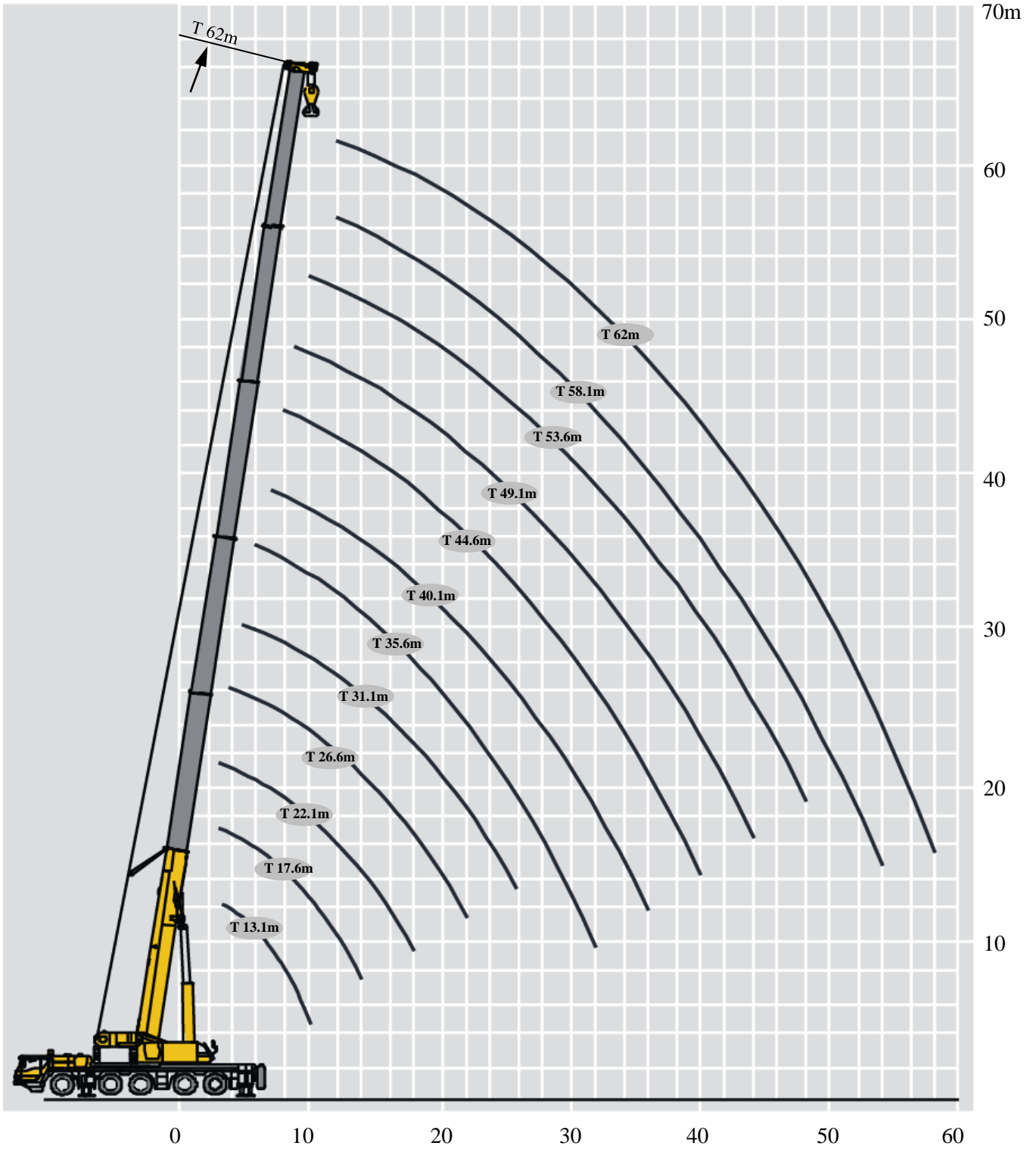

起重性能表

Lifting capacities

T 13.1~62m

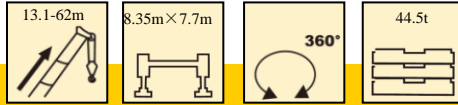



	13.1	17.6m	17.6m	17.6m	22.1m	22.1m	22.1m	26.6m	26.6m	26.6m	
3	130.0*	83.0	83.0	58.0	83.0	83.0	61.7				3
3.5	101.0	83.0	83.0	54.8	83.0	83.0	59.0				3.5
4	93.0	83.0	83.0	52.0	83.0	83.0	56.3	67.0	67.0	58.8	4
4.5	86.0	83.0	83.0	49.6	82.0	82.0	53.7	67.0	67.0	56.6	4.5
5	81.0	78.0	79.0	47.3	76.0	77.0	51.5	67.0	67.0	54.4	5
6	71.0	69.0	69.0	43.4	67.0	68.0	47.5	66.0	66.5	50.7	6
7	62.0	61.0	62.0	40.0	60.0	61.0	44.4	59.0	59.0	47.4	7
8	55.0	55.0	56.0	37.2	54.0	55.0	41.6	53.0	54.0	44.7	8
9	47.0	50.0	50.0	34.9	49.0	50.0	38.7	48.0	49.0	42.1	9
10	38.0	45.0	45.6	32.6	44.0	45.0	35.9	44.0	45.0	39.9	10
12		36.0	36.8	29.3	36.0	37.0	30.9	36.7	37.1	35.2	12
14		27.0	27.0	26.8	29.0	30.2	27.2	29.8	30.3	31.3	14
16					23.2	24.3	24.4	24.0	24.5	26.4	16
18					19.0	20.1	21.8	19.8	20.3	22.1	18
20								16.5	17.0	18.8	20
22								14.0	14.5	16.2	22
组合 Code	00000	01000	00100	00001	11000	01100	00011	11100	02100	00111	组合 Code

	31.1m	31.1m	31.1m	35.6m	35.6m	35.6m	40.1m	40.1m	40.1m	
5	58.0	56.3	48.1							5
6	58.0	52.9	43.6	50.0	50.0	49.2				6
7	58.0	49.7	39.6	50.0	50.0	45.4	42.0	42.0	32.0	7
8	53.0	47.0	35.8	50.0	48.8	41.8	42.0	41.8	30.0	8
9	48.0	44.8	32.9	46.7	46.3	38.5	42.0	39.1	28.3	9
10	44.0	42.6	30.6	43.0	44.0	35.0	40.3	35.3	26.8	10
12	37.4	38.6	26.6	37.0	38.0	30.0	34.0	31.0	23.9	12
14	30.7	32.1	23.6	30.3	31.5	26.6	29.6	27.8	21.6	14
16	24.8	26.2	21.0	24.5	25.7	23.7	25.3	25.2	19.8	16
18	20.6	21.9	18.9	20.3	21.4	21.4	21.0	21.3	18.1	18
20	17.4	18.6	17.2	17.0	18.1	18.5	17.8	18.1	16.8	20
22	14.8	16.1	15.9	14.5	15.6	15.9	15.2	15.5	15.6	22
24	12.8	14.0	14.3	12.5	13.5	13.9	13.2	13.5	14.1	24
26	11.1	12.3	12.6	10.8	11.8	12.2	11.5	11.8	12.4	26
28				9.3	10.4	10.7	10.1	10.4	11.0	28
30				8.1	9.2	9.5	8.8	9.1	9.8	30
32				7.0	8.0	8.0	7.8	8.1	8.7	32
34							6.9	7.2	7.8	34
36							6.1	6.4	7.0	36
组合 Code	11110	01111	00211	21110	11111	02111	21111	12111	11112	组合 Code

起重性能表

Lifting capacities

T 13.1~62m

	44.6m	44.6m	44.6m	49.1m	49.1m	49.1m	53.6m	53.6m	58.1m	62m	
8	32.7	31.7	24.0								
9	32.7	30.9	22.7	25.1	24.2	21.3					9
10	32.9	29.3	21.5	25.1	24.2	20.5	18.7	18.1			10
12	29.7	26.5	19.3	25.1	22.9	18.8	17.8	18.1	14.7	11.8	12
14	26.7	24.0	17.5	22.6	21.0	17.4	16.8	18.1	14.8	11.8	14
16	23.5	21.7	15.9	20.1	19.0	16.0	15.8	16.7	14.8	11.9	16
18	21.0	19.9	14.6	17.8	17.0	14.8	14.7	14.9	14.2	12.0	18
20	17.8	18.1	13.4	16.1	15.4	13.7	13.9	13.6	12.9	11.7	20
22	15.2	15.7	12.5	14.6	14.0	12.8	12.8	12.3	11.6	10.6	22
24	13.2	13.7	11.6	13.2	12.8	12.0	11.7	11.3	10.5	9.6	24
26	11.5	12.0	10.9	11.7	11.7	11.2	10.7	10.4	9.6	8.8	26
28	10.0	10.5	10.1	10.2	10.8	10.6	9.8	9.6	8.9	8.1	28
30	8.8	9.3	9.6	9.0	9.6	10.0	9.0	8.9	8.2	7.5	30
32	7.8	8.3	9.0	8.0	8.6	9.1	8.3	8.2	7.6	6.8	32
34	6.9	7.4	8.1	7.1	7.7	8.2	7.4	7.7	7.0	6.4	34
36	6.1	6.6	7.3	6.3	6.9	7.4	6.6	7.1	6.5	5.9	36
38	5.4	5.9	6.6	5.6	6.2	6.7	5.9	6.6	6.1	5.5	38
40	4.7	5.2	6.0	4.9	5.5	6.0	5.3	5.9	5.6	5.1	40
42				4.4	5.0	5.5	4.7	5.4	5.1	4.7	42
44				3.9	4.5	5.0	4.2	4.8	4.5	4.3	44
46							3.7	4.4	4.1	4.0	46
48							3.3	3.9	3.6	3.7	48
50									3.3	3.3	50
52									2.9	2.9	52
54									2.6	2.6	54
56										2.3	56
58										1.6	58
组合 Code	22111	12211	11122	22211	12221	11222	22221	12222	22222	33333	组合 Code

起重性能表

Lifting capacities

T 13.1~62m

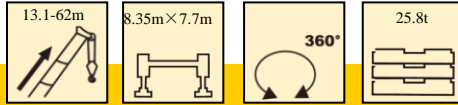



	13.1	17.6m	17.6m	17.6m	22.1m	22.1m	22.1m	26.6m	26.6m	26.6m	
3	105.0 *	83	83	58	83	83	61.7				3
3.5	101.0 *	83	83	54.8	83	83	59				3.5
4	93.0 *	83	83	52	83	83	56.3	67	67	58.8	4
4.5	85.4 *	83	83	49.6	82	82	53.7	67	67	56.6	4.5
5	78.7	78	79	47.3	76	77	51.5	67	67	54.4	5
6	54.4	54.6	55.5	43.4	54.2	55.8	47.5	55.3	56	50.7	6
7	40.6	40.8	41.7	40	40.4	41.9	44.2	41.4	42.1	44.5	7
8	31.9	32	32.8	34	31.7	33.1	35.2	32.6	33.2	35.5	8
9	25.8	25.9	26.7	27.8	25.6	26.9	28.9	26.5	27.1	29.2	9
10	21.3	21.5	22.2	23.3	21.2	22.5	24.3	22	22.6	24.6	10
12		15.4	16.1	17.1	15.1	16.3	18.1	15.9	16.4	18.3	12
14		11.4	12	13	11.2	12.3	14	11.9	12.4	14.2	14
16					8.4	9.4	11.1	9.1	9.6	11.4	16
18					6.3	7.3	9	7	7.5	9.2	18
20								5.4	5.9	7.6	20
22								4.1	4.6	6.2	22
组合 Code	00000	01000	00100	00001	11000	01100	00011	11100	02100	00111	组合 Code

	31.1m	31.1m	31.1m	35.6m	35.6m	35.6m	40.1m	40.1m	40.1m	
5	58	56.3	48.1							5
6	56.5	52.9	43.6	50	50	49.2				6
7	42.5	44.3	39.6	42.1	43.6	44.1	42	42	32	7
8	33.6	35.3	35.7	33.2	34.7	35.1	34.2	34.6	30	8
9	27.5	29	29.4	27.1	28.4	28.9	28	28.4	28.3	9
10	23	24.4	24.8	22.6	23.9	24.3	23.4	23.8	24.6	10
12	16.8	18.2	18.5	16.4	17.6	18	17.2	17.6	18.3	12
14	12.7	14.1	14.4	12.4	13.6	13.9	13.2	13.5	14.2	14
16	9.9	11.2	11.5	9.6	10.7	11.1	10.3	10.6	11.3	16
18	7.8	9.1	9.4	7.5	8.6	8.9	8.2	8.5	9.2	18
20	6.2	7.4	7.7	5.9	6.9	7.3	6.6	6.9	7.5	20
22	4.9	6.1	6.4	4.6	5.6	6	5.3	5.6	6.2	22
24	3.8	5	5.4	3.5	4.6	4.9	4.2	4.5	5.1	24
26	2.9	4.1	4.5	2.7	3.7	4	3.3	3.6	4.3	26
28				1.9	2.9	3.3	2.6	2.9	3.5	28
30				1.3	2.3	2.6	2	2.3	2.9	30
32					1.8	2.1	1.4	1.7	2.3	32
34								1.2	1.8	34
36									1.4	36
组合 Code	11110	01111	00211	21110	11111	02111	21111	12111	11112	组合 Code

起重性能表

Lifting capacities

T 13.1~62m

	44.6m	44.6m	44.6m	49.1m	49.1m	49.1m	53.6m	53.6m	58.1m	62m	
8	32.7	31.7	24								
9	28	28.6	22.7	25.1	24.2	21.3					9
10	23.4	24	21.5	23.7	24.2	20.5	18.7	18.1			10
12	17.2	17.8	18.7	17.4	18.2	18.7	17.8	18.1	14.7	11.8	12
14	13.2	13.7	14.5	13.4	14.1	14.6	13.7	14.5	14.2	11.8	14
16	10.3	10.8	11.6	10.5	11.2	11.7	10.9	11.6	11.3	11.3	16
18	8.2	8.7	9.5	8.4	9.1	9.6	8.7	9.5	9.1	9.2	18
20	6.6	7.1	7.8	6.8	7.4	7.9	7.1	7.8	7.5	7.5	20
22	5.3	5.8	6.5	5.5	6.1	6.6	5.8	6.5	6.2	6.2	22
24	4.2	4.7	5.4	4.4	5	5.5	4.7	5.4	5.1	5.1	24
26	3.3	3.8	4.6	3.5	4.1	4.6	3.8	4.5	4.2	4.3	26
28	2.6	3.1	3.8	2.8	3.4	3.9	3.1	3.8	3.5	3.5	28
30	2	2.4	3.2	2.2	2.8	3.2	2.5	3.1	2.8	2.9	30
32	1.4	1.9	2.6	1.6	2.2	2.7	1.9	2.6	2.3	2.3	32
34		1.4	2.1	1.1	1.7	2.2	1.4	2.1	1.8	1.8	34
36			1.7		1.3	1.8	1	1.7	1.4	1.4	36
38			1.3			1.4		1.3		1	38
40						1.1					40
组合 Code	22111	12211	11122	22211	12221	11222	22221	12222	22222	33333	组合 Code

起重性能表

Lifting capacities

T 13.1~62m

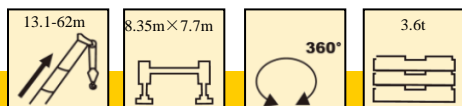

	13.1m	17.6m	17.6m	17.6m	22.1m	22.1m	22.1m	26.6m	26.6m	26.6m	
3	103.2	83.0	83.0	58.0	83.0	83.0	61.7				3
3.5	92.6	83.0	83.0	54.8	83.0	83.0	59.0				3.5
4	83.9	83.0	83.0	52.0	83.0	83.0	56.3	67.0	67.0	58.8	4
4.5	76.5	76.6	77.1	49.6	76.4	77.2	53.7	67.0	67.0	56.6	4.5
5	70.3	70.3	70.8	47.3	70.1	71.0	51.5	67.0	67.0	54.4	5
6	59.6	59.7	60.3	43.4	59.4	60.5	47.5	60.2	60.6	50.7	6
7	42.3	42.5	43.6	40.0	42.1	43.9	44.4	43.3	44.1	47.0	7
8	31.2	31.5	32.5	34.1	31.0	32.8	35.6	32.2	33.1	36.0	8
9	23.7	23.9	24.8	26.2	23.5	25.2	27.6	24.6	25.3	28.0	9
10	18.5	18.8	19.7	21.0	18.5	20.0	22.2	19.5	20.1	22.6	10
12		12.3	13.1	14.3	12.0	13.4	15.4	13.0	13.6	15.8	12
14		8.4	9.1	10.2	8.2	9.4	11.3	9.0	9.6	11.6	14
16					5.5	6.7	8.6	6.4	6.9	8.9	16
18					3.6	4.8	6.6	4.5	5.0	6.9	18
20								3.0	3.5	5.4	20
22								1.9	2.4	4.2	22
组合 Code	00000	01000	00100	00001	11000	01100	00011	11100	02100	00111	组合 Code

	31.1m	31.1m	31.1m	35.6m	35.6m	35.6m	40.1m	40.1m	40.1m	
5	58.0	56.3	48.1							5
6	58.0	52.9	43.6	50.0	50.0	49.2				6
7	44.6	46.8	39.6	44.1	45.9	45.4	42.0	42.0	32.0	7
8	33.6	35.7	35.8	33.0	34.9	35.5	34.3	34.8	30.0	8
9	25.8	27.7	28.3	25.3	27.0	27.6	26.4	26.9	27.9	9
10	20.6	22.4	22.8	20.1	21.7	22.2	21.2	21.6	22.5	10
12	14.0	15.6	16.0	13.6	15.0	15.4	14.5	14.9	15.7	12
14	9.9	11.4	11.8	9.6	10.9	11.3	10.4	10.8	11.6	14
16	7.3	8.7	9.1	6.9	8.1	8.5	7.7	8.1	8.8	16
18	5.3	6.7	7.1	5.0	6.2	6.5	5.8	6.1	6.8	18
20	3.9	5.2	5.6	3.5	4.7	5.1	4.3	4.6	5.3	20
22	2.7	4.0	4.4	2.4	3.5	3.9	3.2	3.5	4.2	22
24	1.8	3.1	3.4	1.5	2.6	3.0	2.2	2.6	3.2	24
26	1.1	2.3	2.7		1.9	2.2	1.5	1.8	2.5	26
28					1.2	1.6		1.2	1.8	28
30						1.0			1.3	30
组合 Code	11110	01111	00211	21110	11111	02111	21111	12111	11112	组合 Code

起重性能表

Lifting capacities

T 13.1~62m

	44.6m	44.6m	44.6m	49.1m	49.1m	49.1m	53.6m	53.6m	58.1m	62m	
8	32.7	31.7	24.0								
9	26.4	27.2	22.7	25.1	24.2	21.3					9
10	21.1	21.9	21.5	21.4	22.4	20.5	18.7	18.1			10
12	14.5	15.1	16.1	14.7	15.6	16.2	15.2	16.1	14.7	11.8	12
14	10.4	11.0	12.0	10.7	11.4	12.1	11.1	11.9	11.5	11.6	14
16	7.7	8.3	9.2	7.9	8.7	9.3	8.3	9.1	8.8	8.8	16
18	5.8	6.3	7.2	6.0	6.7	7.3	6.3	7.1	6.8	6.8	18
20	4.3	4.8	5.7	4.5	5.2	5.7	4.9	5.6	5.3	5.3	20
22	3.1	3.7	4.5	3.4	4.0	4.6	3.7	4.4	4.1	4.2	22
24	2.2	2.8	3.5	2.4	3.1	3.6	2.8	3.5	3.2	3.2	24
26	1.5	2.0	2.8	1.7	2.3	2.9	2.0	2.7	2.4	2.5	26
28		1.4	2.1	1.1	1.7	2.2	1.4	2.1	1.8	1.8	28
30			1.6		1.1	1.7		1.5	1.2	1.3	30
32			1.1			1.2		1.1			32
组合 Code	22111	12211	11122	22211	12221	11222	22221	12222	22222	33333	组合 Code

起升高度曲线图 Lifting height chart

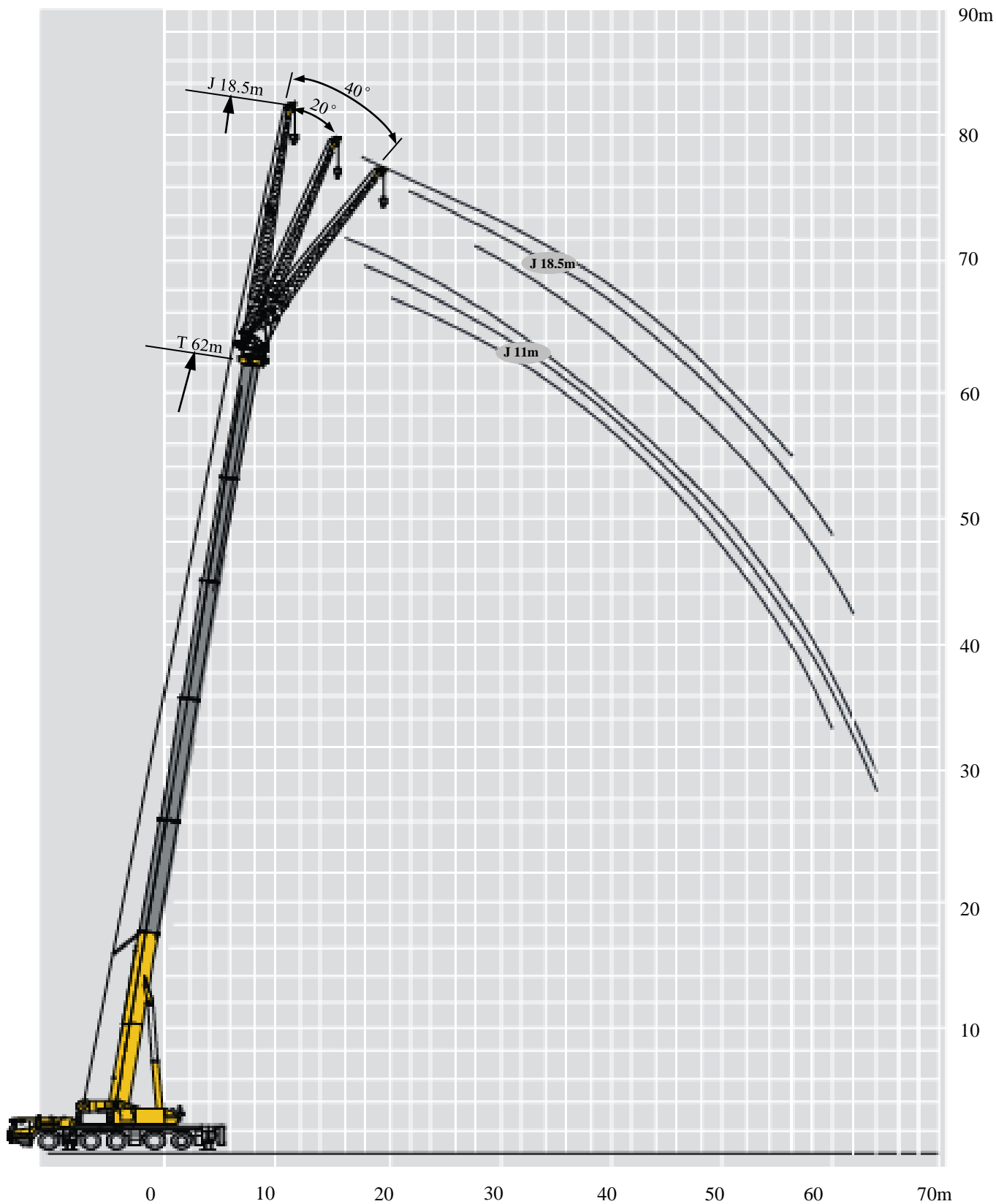

副臂
Jib



起重性能表

Lifting capacities

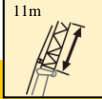

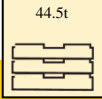

J 11m/18.5 m

	    															
	13.1m			40.1m			53.6 m			58.1m			62m			
	0°	20°	40°	0°	20°	40°	0°	20°	40°	0°	20°	40°	0°	20°	40°	
5	17.3															5
6	17.3	11.6														6
7	16.5	10.1														7
8	15.2	9.0														8
9	14.0	8.6	5.9	13.0												9
10	12.7	8.1	5.6	12.5												10
12	11.5	7.1	5.1	12.0	10.0		10.4									12
14	9.8	6.6	4.9	11.0	9.1		10.4			8.9						14
16	9.0	6.1	4.7	10.5	8.7	5.6	10.3	9.5		8.7			7.9			16
18	6.8	5.6	4.6	10.0	8.2	5.4	10.1	8.7	5.5	8.5	8.6		7.9	7.9		18
20		4.7	4.5	9.5	7.7	5.2	9.9	8.5	5.3	8.4	8.3	5.1	7.9	7.8	5.1	20
22				9.2	7.4	5.0	9.6	8.0	5.1	8.4	7.9	5.0	7.9	7.7	5.0	22
24				8.9	7.0	4.9	9.3	7.5	5.0	8.3	7.6	4.9	7.8	7.6	4.9	24
26				8.6	6.8	4.8	9.3	7.4	4.9	8.3	7.3	4.8	7.8	7.2	4.8	26
28				8.3	6.4	4.7	8.6	6.9	4.8	7.8	7.0	4.7	7.0	6.7	4.7	28
30				8.1	6.2	4.5	7.9	6.8	4.7	7.1	6.6	4.6	6.5	6.2	4.5	30
32				8.0	6.0	4.4	7.3	6.5	4.5	6.5	6.3	4.4	5.9	5.6	4.4	32
34				7.2	5.7	4.3	6.8	6.3	4.4	6.0	5.7	4.3	5.4	5.4	4.3	34
36				6.4	5.6	4.2	6.2	6.0	4.3	5.5	5.3	4.2	4.9	4.9	4.2	36
38				5.7	5.3	4.1	5.7	5.5	4.2	5.0	5.1	4.1	4.6	4.6	4.1	38
40				5.1	5.2	4.1	5.1	5.2	4.0	4.8	4.7	3.9	4.1	4.1	3.9	40
42				4.6	4.7	3.9	4.5	4.7	4.0	4.4	4.3	3.9	3.8	3.8	3.8	42
44					4.2		4.0	4.3	3.9	4.0	4.0	3.8	3.6	3.5	3.5	44
46							3.6	3.8	3.8	3.7	3.7	3.8	3.3	3.3	3.2	46
48							3.2	3.4	3.5	3.4	3.5	3.5	3.0	3.0	2.9	48
50							2.8	3.0	3.0	3.0	3.2	3.3	2.7	2.7	2.8	50
52							2.4	2.6	2.6	2.6	2.8	2.9	2.5	2.5	2.5	52
54							2.1	2.3		2.3	2.5	2.5	2.3	2.3	2.4	54
56							1.8	1.9		2.0	2.2	2.2	2.0	2.1	2.1	56
58										1.8	1.9		1.7	1.8	1.9	58
60										1.5	1.6		1.5	1.6	1.6	60
62													1.2	1.3		62
64													1.0	1.1		64
组合 Code	00000			21111			22221			22222			33333			组合 Code

起重性能表

Lifting capacities

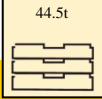

J 11m/18.5 m

	    															
	13.1m			40.1m			53.6 m			58.1m			62m			
	0°	20°	40°	0°	20°	40°	0°	20°	40°	0°	20°	40°	0°	20°	40°	
5	7.8															5
6	7.5															6
7	7.4															7
8	7.2															8
9	7.1															9
10	6.9	6.0														10
12	5.9	5.4		5.6												12
14	5.1	4.7		5.5			4.9									14
16	4.6	4.2	2.5	5.4	4.2		4.8			4.5						16
18	4.1	4.1	2.4	5.3	4.1		4.8			4.4			4.0			18
20	3.7	3.8	2.3	5.2	3.8		4.7	4.1		4.4			4.0			20
22	3.4	3.6	2.1	5.1	3.6	2.4	4.7	3.9		4.4	3.9		4.0	3.7		22
24		3.4	2.0	5.1	3.4	2.3	4.6	3.7	2.4	4.3	3.8		3.9	3.5		24
26			1.9	5.1	3.2	2.2	4.5	3.6	2.3	4.3	3.6	2.3	3.8	3.4		26
28				5.0	3.1	2.1	4.5	3.3	2.2	4.3	3.4	2.2	3.7	3.3	2.2	28
30				4.7	3.0	2.0	4.4	3.2	2.1	4.2	3.3	2.1	3.6	3.2	2.1	30
32				4.5	2.9	2.0	4.4	3.1	2.1	4.2	3.2	2.1	3.5	3.1	2.1	32
34				4.2	2.7	1.9	4.3	3.0	2.0	4.1	3.0	2.1	3.4	3.0	2.0	34
36				4.0	2.6	1.9	4.3	2.9	2.0	4.1	2.9	2.0	3.3	2.8	2.0	36
38					2.5	1.9	4.2	2.7	2.0	4.0	2.8	2.0	3.2	2.7	2.0	38
40					2.3	1.9	4.1	2.6	1.9	4.0	2.7	2.0	3.2	2.6	2.0	40
42					2.2	1.8	4.1	2.5	1.9	3.8	2.5	1.9	3.1	2.5	1.9	42
44					2.1	1.8	3.9	2.4	1.9	3.8	2.4	1.9	3.0	2.5	1.9	44
46						1.8	3.7	2.4	1.9	3.6	2.4	1.9	2.9	2.4	1.9	46
48							3.5	2.3	1.8	3.3	2.4	1.9	2.8	2.4	1.9	48
50							3.2	2.2	1.9	3.0	2.3	1.9	2.6	2.4	1.9	50
52								2.1	1.9	2.7	2.3	1.8	2.3	2.3	1.8	52
54								2.1	1.8	2.5	2.2	2.0	2.3	2.2	1.9	54
56									1.9	2.3	2.1	1.8	2.0	2.0	1.9	56
58										2.1	2.0	1.8		1.9	1.8	58
60										1.8	2.0			1.7	1.8	60
62										1.6	1.8				1.5	62
64										1.4	1.5					64
66											1.3					66
68											1.1					68
组合 Code	00000			21111			22221			22222			33333			组合 Code

起重性能表

Lifting capacities

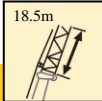
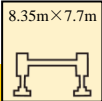
J 11m/18.5 m

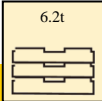
	    															
	13.1m			40.1m			53.6 m			58.1m			62m			
	0°	20°	40°	0°	20°	40°	0°	20°	40°	0°	20°	40°	0°	20°	40°	
5	7.8															5
6	7.5															6
7	7.4															7
8	7.2															8
9	7.1															9
10	6.9	6.0														10
12	5.9	5.4		5.6												12
14	5.1	4.7		5.5			4.9									14
16	4.6	4.2	2.5	5.4	4.2		4.8			4.5						16
18	4.1	4.1	2.4	5.3	4.1		4.8			4.4			4.0			18
20	3.7	3.8	2.3	5.2	3.8		4.7	4.1		4.4			4.0			20
22	3.4	3.6	2.1	4.9	3.6	2.4	4.6	3.9		4.4	3.9		4.0	3.7		22
24		3.4	2.0	3.9	3.4	2.3	3.6	3.7	2.4	3.8	3.8		3.7	3.5		24
26			1.9	3.1	3.2	2.2	2.8	3.6	2.3	3.0	3.6	2.3	2.9	3.4		26
28				2.4	3.1	2.1	2.2	3.2	2.2	2.3	3.3	2.2	2.2	3.2	2.2	28
30				1.8	2.6	2.0	1.6	2.5	2.1	1.7	2.6	2.1	1.7	2.6	2.1	30
32				1.3	2.1	2.0	1.1	1.9	2.1	1.3	2.1	2.1	1.2	2.0	2.1	32
34				0.9	1.6	1.9	0.7	1.4	2.0	0.8	1.6	2.1	0.8	1.5	2.0	34
36				0.5	1.1	1.6		1.0	1.5	0.5	1.2	1.7		1.1	1.7	36
38					0.7	1.1		0.6	1.1		0.8	1.3		0.7	1.2	38
40						0.7			0.7			0.9			0.8	40
42												0.5			0.5	42
组合 Code	00000			21111			22221			22222			33333			组合 Code

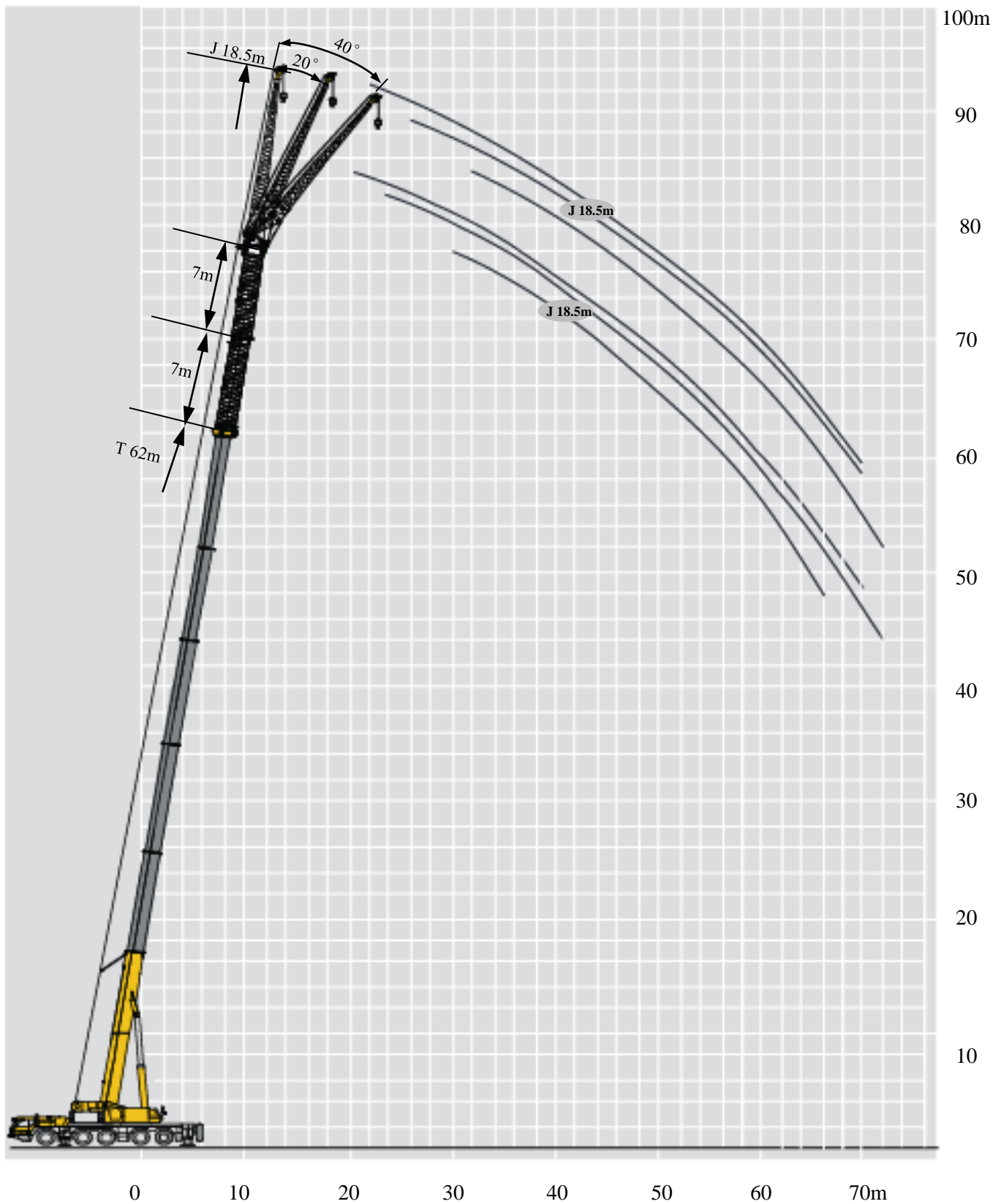

起重性能表

Lifting capacities

J 11m/18.5 m

	58.1+7m			62+7m			
	0°	20°	40°	0°	20°	40°	
18	4.0						18
20	4.0			3.5			20
22	4.0			3.4			22
24	3.9	4.1		3.4	3.3		24
26	3.9	3.9		3.4	3.3		26
28	3.9	3.6	2.5	3.3	3.3		28
30	3.8	3.4	2.4	3.3	3.3	2.6	30
32	3.8	3.3	2.3	3.3	3.3	2.5	32
34	3.7	3.1	2.2	3.2	3.2	2.4	34
36	3.7	3.0	2.1	3.2	3.1	2.2	36
38	3.6	2.9	2.1	3.1	3.0	2.1	38
40	3.6	2.8	2.1	3.1	3.0	2.0	40
42	3.5	2.7	2.0	3.0	2.9	2.0	42
44	3.5	2.6	2.0	2.8	2.6	2.0	44
46	3.0	2.5	2.0	2.5	2.6	2.0	46
48	3.0	2.5	2.0	2.5	2.6	2.0	48
50	2.5	2.4	1.9	2.0	2.1	2.0	50
52	2.3	2.4	1.9	2.0	2.1	1.9	52
54	1.6	2.2	1.9	1.8	1.9	1.9	54
56	1.5	2.1	1.9	1.6	1.8	1.9	56
58	1.5	1.8	1.9	1.6	1.6	1.4	58
60	1.2	1.6	1.2	1.5	0.8	1.4	60
62	1.5	1.4	1.2	1.1	0.8	1.3	62
64	1.0	1.4	1.2	0.5	0.5	0.8	64
66		1.2	1.2	0.5	0.5	0.5	66
68			0.8	0.5	0.5		68
70				0.5	0.5		70
72					0.5		72
组合 Code	22222			33333			组合 Code

起重性能表

Lifting capacities



J 11m/18.5 m



	58.1+14m			62+14m			
	0°	20°	40°	0°	20°	40°	
20	3.5						20
22	3.5			3.0			22
24	3.5			3.0			24
26	3.4	3.4		3.0	2.9		26
28	3.4	3.3		3.0	2.8		28
30	3.4	3.3	2.4	3.0	2.8		30
32	3.3	3.3	2.3	2.9	2.8	2.6	32
34	3.3	3.3	2.3	2.9	2.7	2.5	34
36	3.2	3.2	2.2	2.9	2.7	2.4	36
38	3.2	3.0	2.1	2.9	2.7	2.2	38
40	3.1	2.9	2.1	2.9	2.7	2.1	40
42	3.0	2.9	2.1	2.6	2.7	2.1	42
44	2.6	2.8	2.0	2.3	2.6	2.0	44
46	2.5	2.6	2.0	2.3	2.1	2.0	46
48	2.4	2.3	2.0	1.8	2.1	2.0	48
50	2.1	2.1	2.0	1.8	1.9	2.0	50
52	1.9	2.1	2.0	1.8	1.7	1.8	52
54	1.7	1.6	2.0	1.0	1.4	1.5	54
56	1.6	1.6	1.8	1.8	1.8	1.5	56
58	1.5	1.6	1.5	1.6	1.2	1.5	58
60	1.5	1.4	1.5	1.5	1.2	1.5	60
62	1.2	1.5	1.5	1.3	1.2	0.8	62
64	1.2	1.2	1.2	1.1	0.8	0.8	64
66	1.0	1.2	1.2	0.9	0.8	0.8	66
68	0.8	0.8	0.8	0.7	0.8	0.5	68
70			0.8	0.5	0.5	0.5	70
72						0.5	72
组合 Code	22222			33333			组合 Code

起重性能表

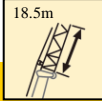
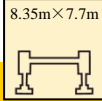
Lifting capacities

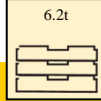
J 11m/18.5 m

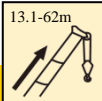
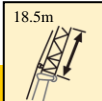
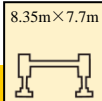
	    						
	58.1+7m			62+7m			
	0°	20°	40°	0°	20°	40°	
18	4.0						18
20	4.0			3.5			20
22	4.0			3.4			22
24	3.8	4.1		3.4	3.3		24
26	3.0	3.9		2.9	3.3		26
28	2.3	3.3	2.5	2.2	3.3		28
30	1.8	2.7	2.4	1.7	2.6	2.6	30
32	1.3	2.1	2.3	1.2	2.0	2.5	32
34	0.8	1.6	2.2	0.7	1.5	2.2	34
36	0.5	1.2	1.7		1.1	1.7	36
38		0.8	1.3		0.7	1.3	38
40			0.9			0.9	40
42			0.6				42
组合 Code	22222			33333			组合 Code

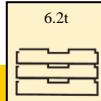
	    						
	58.1+14m			62+14m			
	0°	20°	40°	0°	20°	40°	
20	3.5						20
22	3.5			3.0			22
24	3.5			3.0			24
26	3.0	3.4		2.9	2.9		26
28	2.3	3.3		2.2	2.8		28
30	1.7	2.7	2.4	1.6	2.6		30
32	1.2	2.1	2.3	1.1	2.0	2.6	32
34	0.8	1.6	2.3	0.7	1.5	2.2	34
36		1.2	1.8		1.1	1.7	36
38		0.8	1.3		0.7	1.3	38
40			0.9			0.9	40
42			0.6			0.5	42
组合 Code	22222			33333			组合 Code

符号标识

Symbol glossary

常规标识

General symbols

	上车 Superstructure		底盘 Chassis
	起重能力 Lifting capacity		车桥 Axle
	吊臂长度 Boom length		行驶速度 Driving speed
	工作幅度 Radius		爬坡能力 Grade ability
	吊臂仰角 Boom angle		轮胎 Tires
	主臂起升高度 Boom hoist height		支腿 Outriggers
	固定副臂长度 Fixed jib length		吊钩 Hook block
	副臂安装角 Jib offset angle		平衡重 Counterweight
	副臂起升高度 Jib hoist height		卷扬 Winch
	独立臂头 Independent jib head		360°全回转 360° rotation
	主臂加长节 Boom extension		

主要技术参数表

Table of main technical parameters

类别 Category	项目 Item	单位 Unit	参数 Parameter		
尺寸参数 Dimensions	外形尺寸 (长×宽×高) Dimension (length ×width ×height)	mm	15288×2750×3950 (14.0R25) 15288×2750×4000 (16.0R25) 15288×2850×4000 (20.5R25)		
	轴距Wheel base	mm	2500+1650+2100+1650		
	轮距 (前/后) Track (Front/ Rear)	mm	2340 (14.0R25) 2296 (16.0R25) 2308 (20.5R25)		
	前悬/后悬 Front/ Rear overhang	mm	2611/2616		
	前伸/后伸 Front/ Rear extension	mm	2161/0		
重量参数 Weight	最大允许总质量Max. permissible total weight	kg	60000		
	轴荷 Axle load	一轴 1st axle	kg	12000	
		二轴 2nd axle	kg	12000	
		三轴 3rd axle	kg	12000	
		四轴 4th axle	kg	12000	
	五轴 5th axle	kg	12000		
动力参数 Power	发动机型号 Engine model	——	OM471LA(EU Stage IV)	OM471LA(EU Stage V)	
	额定功率/转速 Engine rated power/rpm	kW/(r/min)	360/1700	360/1600	
	最大净功率/转速 Max. net power/rpm	kW/(r/min)	360/1700	360/1600	
	最大输出扭矩/转速 Engine rated torque/rpm	N.m/(r/min)	2300/1300	2400/1300	
行驶参数 Travel	最高车速 Max. travel speed	km/h	80		
	最低稳定车速 Min. stable travel speed	km/h	3		
	最小转弯直径 Min. turning diameter	m	≤18 (小转弯模式Tight-turning radius mode , 五桥转向 five-axle steering) ; ≤22 (公路模式Normal road mode , 五桥转向 five-axle steering)		
	臂头最小转弯直径 Min. turning diameter at boom tip	m	≤23.3 (小转弯模式Tight-turning radius mode , 五桥转向 five-axle steering) ; ≤27.2 (公路模式Normal road mode , 五桥转向 five-axle steering)		
	最小离地间隙 Min. ground clearance	mm	330 (14.0R25) 380 (16.0R25/20.5R25)		
	接近角 Approach angle	°	18 (14.0R25) 19 (16.0R25/20.5R25)		
	离去角 Departure angle	°	14 (14.0R25) 15 (16.0R25/20.5R25)		
	制动距离 (制动初速度为30km/h) Braking distance (at 30 km/h)	m	≤10		
	最大爬坡能力 Max. grade ability	%	60(14.0R25) 60(16.0R25/20.5R25)		
	百公里油耗 Fuel consumption per 100 km	L	65		
噪音 Noise	加速行驶机外噪声 Exterior noise level	dB(A)	84 (ECE R51-03)		
	驾驶员耳旁噪声 Noise level at seated position	dB(A)	90		

主要技术参数表

Table of main technical parameters

类别 Category	项目 Item		单位 Unit	参数 Parameter	
主要性能参数 Main performance	最大额定总起重量 Max. total rated lifting capacity		t	130	
	最小额定工作幅度 Min. rated working radius		m	3	
	转台尾部回转半径 Turning radius at turntable tail	平衡重处 Counterweight	mm	4630/4335	
		副卷处 Auxiliary winch	mm	4600	
	最大起重力矩 Max. load moment	基本臂 Base boom	kN.m	4468	
		最长主臂 Fully-extended boom	kN.m	2297	
		最长主臂+副臂 Fully-extended boom + Jib	kN.m	1976	
	支腿跨距 Outrigger span	纵向 Longitudinal	m	8.35	
		横向 Lateral	m	3.7/5/6.3/7.7	
	起升高度 Hoist height	基本臂 Base boom	m	12.1	
		最长主臂 Fully-extended boom	m	61.5	
		最长主臂+副臂 Fully-extended boom + Jib	m	92.5	
	起重臂长度 Boom length	基本臂 Base boom	m	13.1	
		最长主臂 Fully-extended boom	m	62	
最长主臂+副臂 Fully-extended boom + Jib		m	94.5		
副臂安装角 Jib offset angle		°	0、20、40		
工作速度参数 Working speed	起重臂起臂时间 Boom raising time		s	≤65	
	起重臂全伸时间 Boom fully extended time		s	≤630	
	最大回转速度 Max. slewing speed		r/min	≥1.65	
	支腿收放时间 Outrigger extending and retracting time	水平支腿 Outrigger beam	收 Retracting	s	≤25
			放 Extending	s	≤20
		垂直支腿 Outrigger jack	收 Retracting	s	≤55
			放 Extending	s	≤45
起升速度 (单绳,第四层,空载) Hoisting speed (single line, 4th layer, no load)	主起升机构 Main winch	m/min	≥130		
	副起升机构 Auxiliary winch	m/min	≥130		
噪声 Noise	机外辐射 Exterior noise level		dB (A)	≤109	
	司机位置处 Noise level at seated position		dB (A)	≤80	

主要配套件明细表

Main parts list

序号 N0.	名称 Name	型号 Model	厂家 Manufacturer
1	发动机 Engine	OM471LA	戴姆勒股份公司 Daimler AG
2	变速箱 Transmission	12TX 2616 SO	德国ZF变速箱有限公司 ZF Friedrichshafen AG
3	车桥 Axle	72.7775.3a/72.7909.3/72.7610.3b/ 72.7910.3/72.8124.3a/72.8125.3a FP23CXJ4-1A/FP23CXJ4- 2A/41.3683.2f/41.3684.2e	德国KESLER车桥公司 KESLER & CO. GMBH 重庆大江信达车辆股份有限公司车桥公司 Chongqing Dajiang Xinda Vehicle Company Limited
4	轮胎 Tire	14.00R25, 16.00R25, 20.50R25	青岛泰凯英轮胎有限公司 Techking Tires Limited (14.00R25、16.00R25) 米其林(中国)投资有限公司 (20.50R25) Michelin (China) Investment Co., Ltd. 说明：整机选配20.5R25轮胎时，没有WVTA认证
5	主泵 Main pump	A11V095EP2D/10L+A11V095EP2D /10L A11V095EP2D/10R+A11V095EP2D /10R	博世力士乐有限公司 Bosch Rexroth (China) Co.,LTD.
6	主阀 Main valve	LSJCDF-E	徐州徐工液压件有限公司Xuzhou Hydraulic Parts Co., Ltd. XCMG
7	伸缩油缸 Telescoping cylinder	XCA130.16	徐州徐工液压件有限公司Xuzhou Hydraulic Parts Co., Ltd. XCMG
8	变幅油缸 Elevating cylinder	XCA130.28	成都成缸液压设备制造有限公司 Chengdu Hydraulic Cylinder Co., Ltd.
9	主卷扬减速机 Main winch reducer	CMWA00047	大连华锐重工集团股份有限公司Dalian Huarui Heavy Industry Group Co., Ltd. 徐州圣邦机械有限公司 Xuzhou Shengbang Mechinery Co., Ltd.
10	副卷扬减速机 Auxiliary winch reducer	CMWA00047	
11	回转减速机 Slewing reducer	GMRG16-75	
12	主卷扬马达 Main winch motor	A6VM115EP	博世力士乐有限公司Bosch Rexroth
13	副卷扬马达 Auxiliary winch motor	A6VM115EP	
14	回转支承 Slewing bearing	011.50.1993.101.24.03D1	徐州罗特艾德回转支承有限公司Xuzhou Rothe Erde Slewing Bearing Co., Ltd.
15	力矩限制器 LMI	qSCALE S6	徐州赫思曼电子有限公司 Xuzhou Hirschmann Electronics Co., Ltd.

注意事项

Notes

1. 表中额定总起重量值，是在平整的坚固地面上本起重机能够保证的最大总起重量，包括吊钩和吊具的重量，所以为了估算重物重量，必须减去上述的装置重量。
2. 表中的工作幅度为起吊重物离地时起重物到起重机回转轴线的水平距离，是包括起重臂变形量在内的实际值，因而起吊前应考虑起重臂变形量。
3. 只允许在5级(瞬时风速14.1m/s，风压125N/m²)风以下进行作业。
4. 吊重前操作者必须对物体的重量和工作范围了解后选择合适的作业工况，严禁超出表中的数值。幅度及臂长在相邻两个数值之间时，应依据两个数值中较小值确定起重作业。
5. 应按主臂仰角范围作业，即使是空载，也不应使主臂仰角处于范围外，谨防整机倾翻。
6. 表中的主臂长度应要按照每节臂的伸缩要求进行伸出。
7. 标注*的工况为名义载荷。

1. The total rated loads given in the rated load charts are the maximum lifting capacity when the crane is set up on firm and level ground, which includes the weight of the hook block and slings. The weight of above-mentioned devices should be deducted from the rated lifting load.
2. The working radius shown in the rated load charts is the radius when the load is lifted off the ground, and it is the actual value including loaded boom deflection. Take boom deflection into consideration before beginning a lifting operation.
3. A lifting operation is permissible only when the wind force is below grade 5 (instantaneous wind speed is 14.1 m/s, wind pressure is 125 N/m²).
4. Before beginning lifting operation, the operator should know the weight of the load to be lifted and its working range, and then select proper working conditions. Never operate the crane beyond the limit shown in the chart. Use the lower value from the chart when the boom length or working radius is between the range of values.
5. Observe the boom angle limit. Never operate the crane with the boom angle beyond the recommended limit even if a load is not being carried. Otherwise, the crane will tip.
6. The boom should be extended according to the telescoping code shown by digits, which means the percentage of boom sections extended.
7. The technical data with a * followed are for the nominal load



地址：中国江苏徐州市铜山路165号

Add : No.165 Tongshan Road Xuzhou Jiangsu China

电话(Tel) : +86-516-83462242/83462350

质量监督电话(Quality Inquiry Tel) : +86-516-87888268

备件电话(Spare Parts Tel) : +86-516-83461542

邮编(Post Code) : 221004

网址(Web) : www.xcmg.com/qizhongji

服务热线 Service Tel

400-110-9999

400-001-5678



本印刷品不属于合同。出于产品不断改进的需要，我们保留对产品型号、参数、配置进行变更的权利，恕不另行通知。图片仅供参考，具体产品以实物为准。图片中产品可能并非标准配置，部分部件可能需要另行购置。办理牌照和上路行驶需遵守当地法规。

This print does not belong to the contract. We reserve the right to modify the design (such as product model, parameters and configuration) without notice for improvement. The pictures are just for reference. The product in the picture may not be standard configuration. Some parts need to be purchased separately. Conform to the local laws for license application and road traveling.